

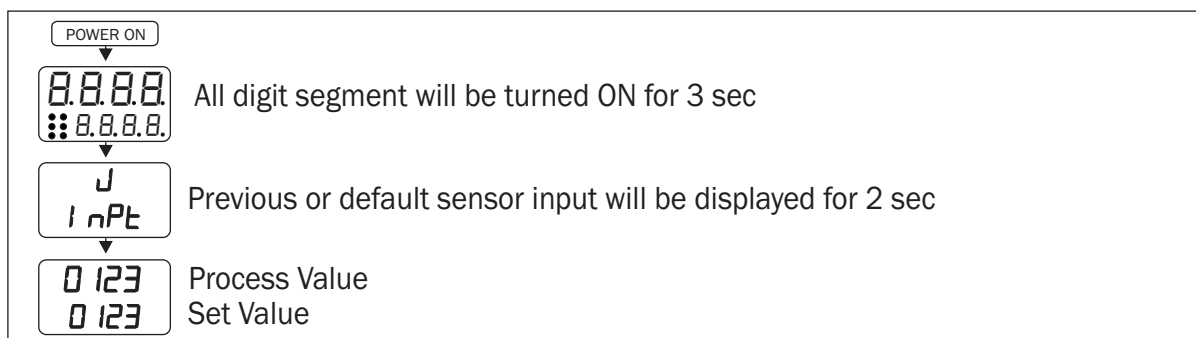

**Technical Specification**

Model	UTC-4201A
Display	UPPER:- 4 Digit 7 seg 0.39",red LED Display LOWER:- 4 Digit 7 seg 0.28",green LED Display
Size(HXWXD)	48 X 48 X 95 mm
Panel Cutout	44 X 44 mm
Input	J, K, PT-100, PT.1
Temperature Range	J: 0 to 600° C / K: 0 to 1200° C / PT-100: -99 to 400°C /PT.1: -99.0 to 400.0° C
Control Action	PID/ON-OFF
Output	1st Output: 4-20mA DC, Controlling Output 2nd Output: 1 Relay (High/Low/Inband/Outband Alarm mode selection)
Power Supply	100 to 250V AC, 50 / 60 Hz, Approx 4VA
Protection Level (As per request)	IP-65(Front side) AS per IS/IEC 60529:2001
Operating Temperature	0° C To 55° C
Relative Humidity	Up to 95% RH Non Condensing

\* Every time the instrument is turned ON, following pattern will be display



**Connection Diagram**

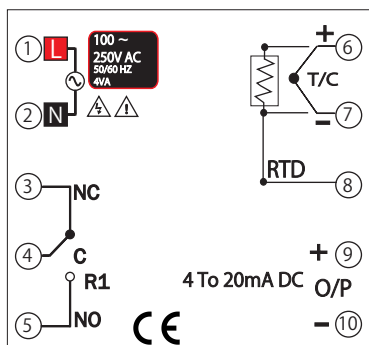

### Basic Configuration

TO ENTER BASIC CONFIGURATION SETTING, ENTER "73"

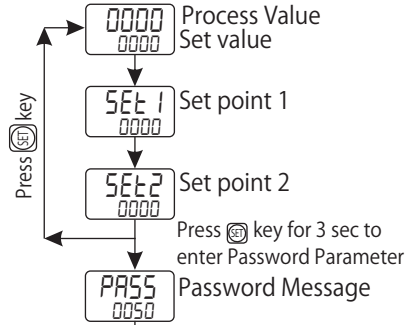
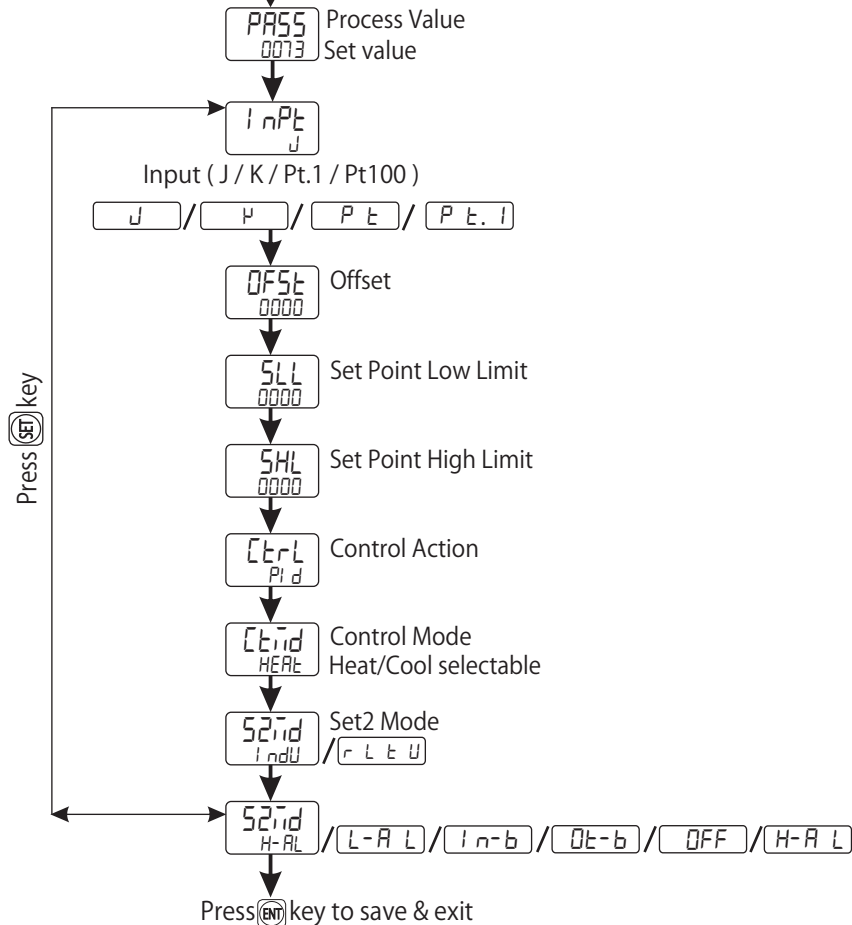

### Key Operation

- 1) Press **SET** key to go parameter setting.
- 2) Press **▲** or **▼** key to change value or to select option.
- 3) Press **ENT** key to save change in setting
- 4) Press **▲** + **▼** key for 3 sec to go to factory setting mode.
- 5) When manual mode selected, using **▲** & **▼** key, we can enter output value 4 to 20mA DC

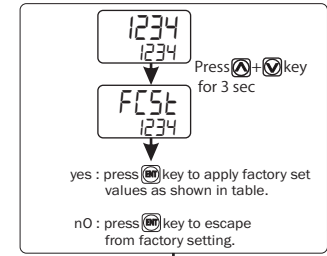

### Control Parameter

TO ENTER CONTROL PARAMETER SETTING, ENTER "37"

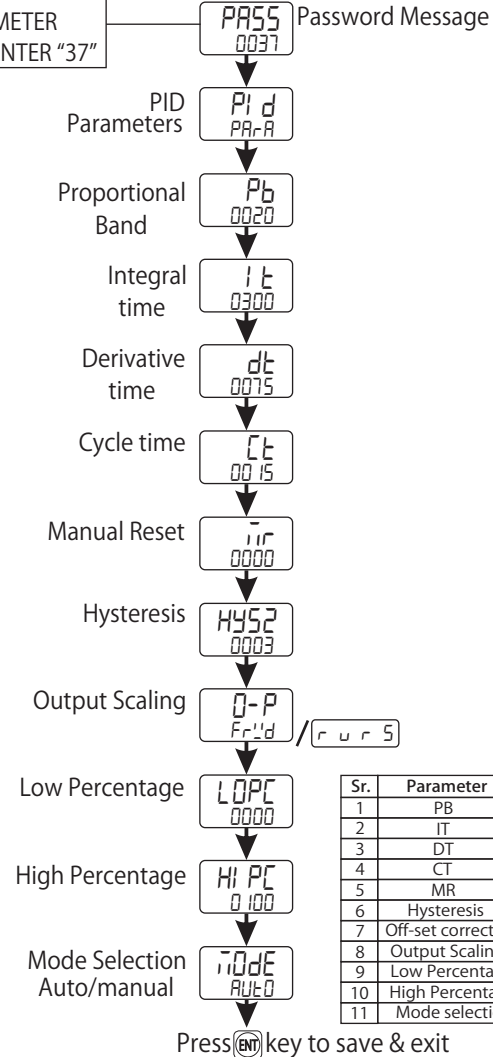

### Factory Setting

FACTORY SETTING		
Sr.	PARAMETER	VALUES
1	PB	0020
2	IT	0300
3	DT	0075
4	CT	15 sec
5	MR	0° C
6	Offset	0° C
7	Output Scaling	Forward
8	Low (%)	000%
9	High (%)	100%
10	Mode	Auto

Sr.	Parameter	Range for J, K, PT100	Range for PT.1
1	PB	0 to 999	
2	IT	0 to 999	
3	DT	0 to 999	
4	CT	4 sec to 99 sec	
5	MR	-9 to +9	-9.0 to +9.0
6	Hysteresis	1°C to 50°C	0.1°C to 50.0°C
7	Off-set correction	-20°C to +20°C	-20.0°C to +20.0°C
8	Output Scaling	Forward/Reverse Sele	
9	Low Percentage	00 to high percentage	
10	High Percentage	Low percentage to 100	
11	Mode selection	Auto/Manual	

## Safety Precautions

All safety related codifications, symbols and instructions that appear in this operating manual or on the equipment must be strictly followed to ensure the safety of the operating personnel as well as the instrument.

If all the equipment is not handled in a manner specified by the manufacturer, it might impair the protection provided by the equipment.

=> Read complete instructions prior to installation and operation of the unit.

 **WARNING** : Risk of electric shock.

## Warning Guidelines

- 1) To prevent the risk of electric shock power supply to the equipment must be kept OFF while doing the wiring arrangement. Do not touch the terminals while power is being supplied.
- 2) To reduce electro magnetic interference, use wire with adequate rating and twists of the same of equal size shall be made with shortest connection.
- 3) Cable used for connection to power source, must have a cross section of 1 mm or greater. These wires should have insulations capacity made of at least 1.5kV.
- 4) A better anti-noise effect can be expected by using standard power supply cable for the instrument.

## Installation Guidelines

- 1) This equipment, being built-in-type, normally becomes a part of main control panel and in such case the terminals do not remain accessible to the end user after installation and internal wiring.
- 2) Do not allow pieces of metal, wire clippings, or fine metallic fillings from installation to enter the product or else it may lead to a safety hazard that may in turn endanger life or cause electrical shock to the operator.
- 3) Circuit breaker or mains switch must be installed between power source and supply terminal to facilitate power 'ON' or 'OFF' function. However this mains switch or circuit breaker must be installed at convenient place normally accessible to the operator.
- 4) Use and store the instrument within the specified ambient temperature and humidity ranges as mentioned in this manual.

## Mechanical Installation

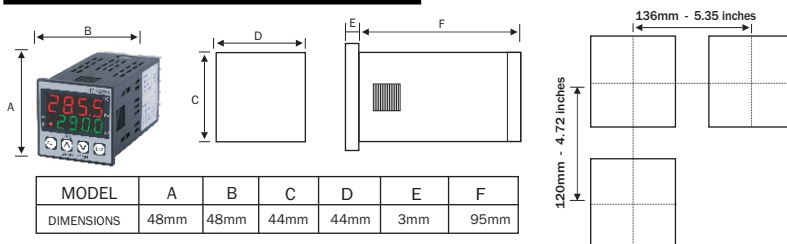

- 1) Prepare the panel cutout with proper dimensions as show above.
- 2) Fit the unit into the panel with the help of clamp given.
- 3) The equipment in its installed state must not come in close proximity to any heating source, caustic vapors, oils steam, or other unwanted process by products.
- 4) Use the specified size of crimp terminal (M3.5 screws) to wire the terminal block. Tightening the screws on the terminal block using the tightening torque of the range of 1.2 N.m.
- 5) Do not connect anything to unused terminals.

## Maintenance

- 1) The equipment should be cleaned regularly to avoid blockage of ventilating parts.
- 2) Clean the equipment with a clean soft cloth. Do not use isopropyl alcohol or any other cleaning agent.
- 3) Fusible resistor must not be replaced by operator.

Product improvement and upgrade is a constant procedure, contact us for more information and Support.

Ver:1807