

Johannesburg Branch

MIMIC COMPONENTS

Cape Town Branch

Mimic Cape

MULTISPAN



PROCESS TEMPERATURE CONTROLLER

PTC-1202A-M1

APPLICATIONS

Pharmaceutical Industries

Extrusion Machinery

Furnace & Boilers

Ovens & Incubators

Process Industry

Mechanical Dimensions

Body Dimensions

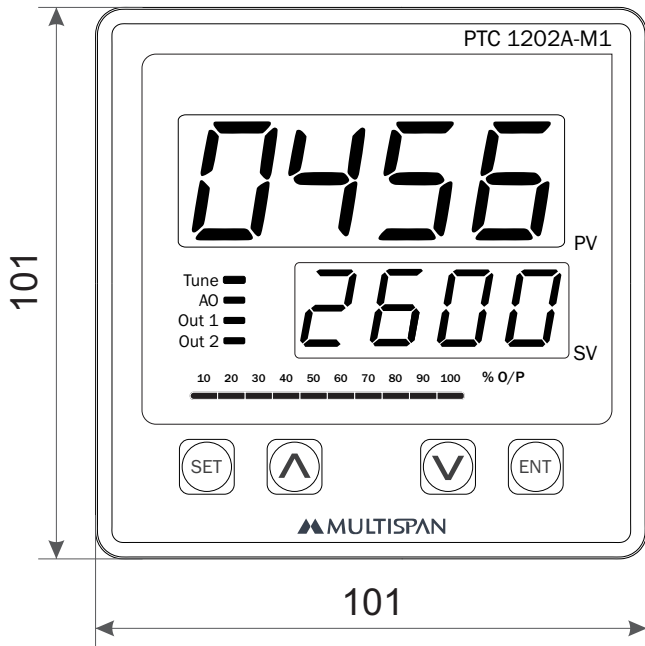

FRONT VIEW

All dimensions are in mm

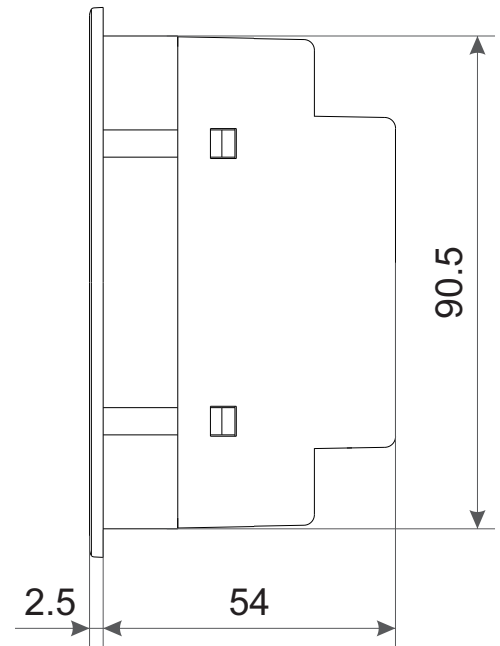

RIGHT SIDE VIEW

Connection Diagram

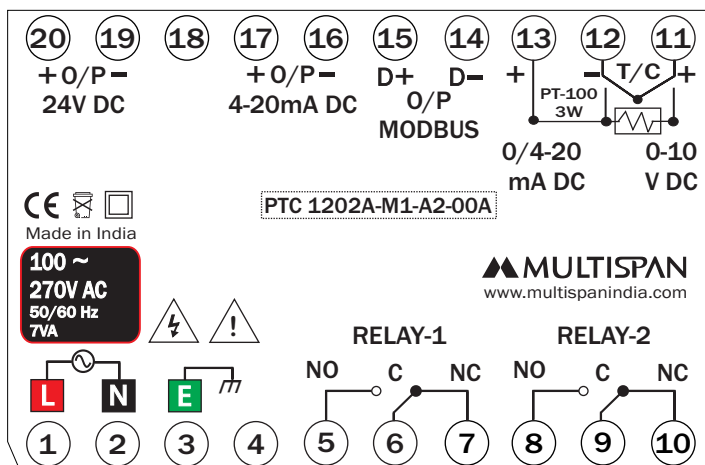

Panel Cutout

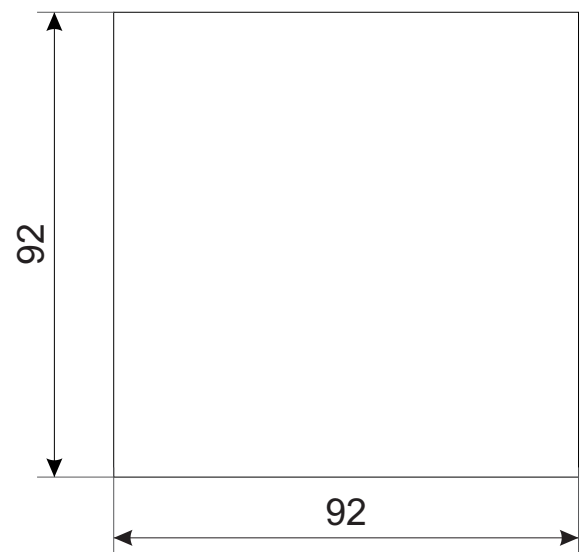

TECHNICAL DATA

Input	Thermocouple	J / K (Configurable)
	RTD	PT-100 / 2 Wire / 3 Wire (Configurable)
	Analog	0-10V DC, 0-20mA DC, 4-20mA DC (Configurable)
Range	Thermocouple	J: (0 to 600 °C), K: (0 to 1200 °C)
	RTD	PT-100: (-99 to 400 °C)/ PT.1: (-99.9 to 400.0 °C)
	Analog	(-1999 to 9999)
Output	Output 1	Relay 1 C/O, 5A@230V AC For Resistive Load or SSR 12V DC,20mA
	Output 2	Relay 1 C/O, 5A@230V AC For Resistive Load or SSR 12V DC,20mA
	Output 3	0 to 10V DC / 4 to 20mA DC (Any one factory set) Controlling or Retrans. (Selectable)
	Output 4	RS-485 RTU MODBUS Communication Protocol
	Output 5	24V DC Transmitter supply
Control Action		Heating : PID / ON-OFF (Configurable) Cooling : ON-OFF / Blower TP (Configurable)
Power Supply		100-270V AC, 50/60 HZ, Approx 7VA
Certification		CE

Table 1 (Input range)

J	0 to 600 °C
K	0 to 1200 °C
PT-100	-99 to 400 °C
PT.1	-99.9 to 400.0 °C
0-10V DC	-1999 to 9999
4-20mA DC	-1999 to 9999
0-20mA DC	-1999 to 9999

Power Supply

Standard	100-270V AC @ 50/60 Hz
Optional	24V DC
Consumption	7VA

Display & Keys

Upper:- 4 Digit, 7 seg. 0.8" RED LED Display
Lower:- 4 Digit, 7 seg. 0.56" White LED Display
SET , INC , DEC , ENT

Communication

Type	RS 485
Protocol	MODBUS RTU
Baud Rate	2400, 4800, 9600, 19200 ,38400
Isolation	2500 V _{RMS} Isolation as per UL 1577

Input

Input Type	Thermocouple : J, K RTD : PT-100, PT.1 Analog : 0-10V DC 4-20mA DC 0-20mA DC
Display Range	Refer (Table 1)
Accuracy	± 1% of FSD
ADC Resolution	12 Bit
Display Resolution	Thermocouple :- 1 °C RTD :- For PT: 1 °C For PT.1: 0.1 °C
Sample Time	600 msec
Sample Rate For Analog I/P	0.1 Sec To 10 Sec (Configurable)
CJC Error	± 2 °C
Sensor Open	Thermocouple:- J, K, RTD:- PT, Analog: 4 to 20mA (Over)
Sensor Burnout Current	1.10uA
RTD Excitation Current	0.2mA
CMRR	>120 dB (Typical)
Max Voltage	20V DC
Response Time	675mS

Output

Control Output		
Control Type	ON-OFF, Auto tune PID	
Proportional Band	0000 to 999.9	
Integral Time	0000 to 9999	
Derivative Time	0000 to 9999	
Cycle Time For SSR and Relay	4 sec to 99 sec	
Relay Control Output		
Relay	2 Nos, 1 C/O (NO-C-NC)	
Rating	Relay 1: 5A @230V AC/ 30V DC Resistive Load Relay 2: 5A @230V AC / 30V DC Resistive Load	
SSR Control Output (Optional)		
Rating	12V DC @20mA	
Analog Output (Controlling or Retrans.) Selectable		
Current	4-20mA DC	Factory Set Any one
Voltage	0-10V DC	

Environmental Characteristics

Operating Temperature	0 to 55 °C
Storage Temperature	0 to 70 °C
Humidity	95% RH Non-condensing
Ingress Protection	IP 65 (Front Side)

Mechanical Characteristics

Mounting Type	Panel Mount
Dimension (HxWxD) mm	101 x 101 x 54
Panel Cutout (HxW) mm	92 x 92
Material	Front Enclosure Polycarbonate (PC) ABS
Terminal Screw Size	M3.5
Screw Torque (N.m)	1
Wire Gauge (AWG)	26-14
Weight (Approx) gms	Unpacked : 260 Packed : 315
Accessories	1 Pair of Clamps

PROCESS & TEMPERATURE CONTROLLER

MULTISPAN

PTC- 1202A-M1



PV = Process value
SV = Set Value

TECHNICAL SPECIFICATION

INPUT SPECIFICATION:

Input Types	Input	Range
	J	0 to 600 °C
	K	0 to 1200 °C
	PT-100	-99 to 400 °C
	PT.1	-99.9 to 400.0 °C
	0-10V DC	-1999 to 9999
	0-20mA DC	-1999 to 9999
	4-20mA DC	-1999 to 9999
Resolution	J,K,PT-100 = 1 °C	
	PT.1 = 0.1 °C	
Indication Accuracy	0-10V DC, 0-20mA DC, 4-20mA DC = 0.1, 0.01, 0.001, 0.001	
	±1% of FSD ± 1 Count (FSD : full scale deflection)	

DISPLAY AND KEYS:

Display	Upper : 4 digit, 7 seg 0.8" RED LED Lower : 4 digit, 7 seg 0.56" Green LED
Keys	SET, INC, DEC, ENT

DIMENSION:

Size	101 (H) x 101 (W) x 54 (D) mm
Panel Cutout	92 (H) x 92 (W) mm

CONTROL METHOD:

Heating	1) PID control with Auto-Tuning 2) ON-OFF control
Cooling	1) BL.TP (Blower Time Proportion) 2) ON-OFF control
Alarm	High/Low/Inband/Outband/ Absolute Low/Absolute Outband

OUTPUT SPECIFICATION

Relay Output	
Relay	2 nos.
Relay Type	1 C/O (NO-C-NC)
Rating	5A, 230V AC/30 V DC
Analog Output	
4 to 20mA DC	
Transmitter supply	
24V DC	
Modbus Communication	
RS-485	

AUXILIARY SUPPLY

Supply voltage	100 to 270V AC, 50-60Hz
Power consumption (VA RATING)	Approx 7 VA @ 230V AC MAX

ENVIRONMENT CONDITION

Operating Temp.	0 °C to 55 °C
Relative Humidity	UP to 95% RH (non-condensing)
Protection Level	IP-65 (Front side) As per IS/IEC 60529 : 2001

MECHANICAL INSTALLATION

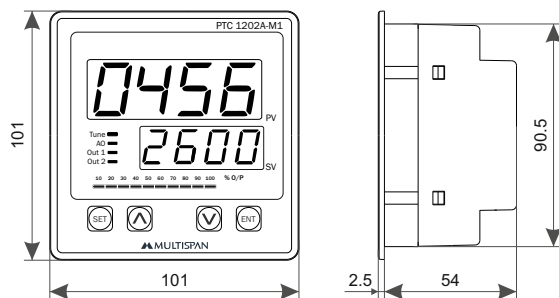

FRONT VIEW

All dimensions are in mm

RIGHT SIDE VIEW

Panel Cutout

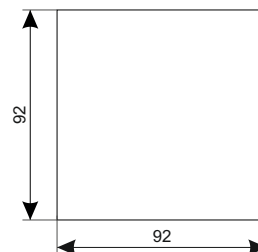

TERMINAL CONNECTION

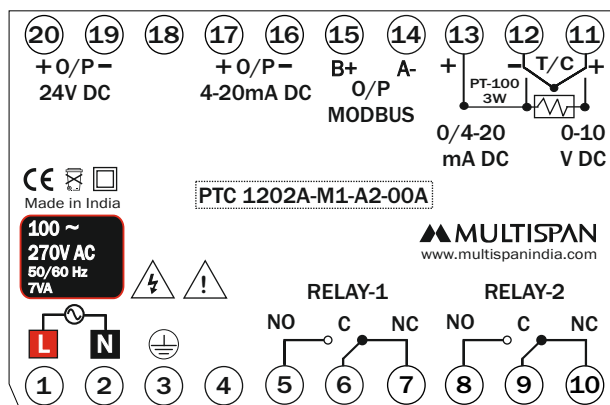

Johannesburg Branch
MIMIC COMPONENTS
Cape Town Branch
Mimic Cape

DISPLAY INDICATION

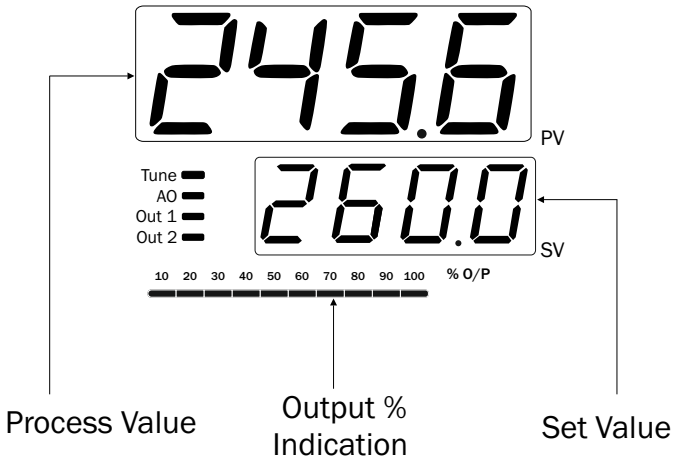

MECHANICAL INSTALLATION GUIDELINES

1. Prepare the panel cutout with proper dimensions as shown above.
2. Fit the unit into the panel with the help of clamp given.
3. The equipment in its installed state must not come in close proximity to any heating source, caustic vapors, oils steam, or other unwanted process byproducts.
4. Use the specified size of crimp terminal (M3.5 screws) to wire the terminal block. Tightening the screws on the terminal block using the tightening torque of the range of 0.5 N.m.
5. Do not connect anything to unused terminals.

MAINTENANCE

1. The equipment should be cleaned regularly to avoid blockage of ventilating parts.
2. Clean the equipment with a clean soft cloth. Do not use isopropyl alcohol or any other cleaning agent.
3. Fusible resistor must not be replaced by operator.

KEY OPERATION

FUNCTION	PRESS KEY
OPERATOR MODE	
To enter in parameter setting	Press for 5 sec
For start/stop PID auto tuning	Press 6 sec
To go in factory setting mode	+ Press 3 sec
To Reset soak process	Long Press
PARAMETER SETTING MODE	
To set parameter value	
To increment parameter value.	
To decrement parameter value.	
Set parameter to be save & exit.	

INSTALLATION GUIDELINES

1. This equipment, being built-in-type, normally becomes a part of main control panel and in such case the terminals do not remain accessible to the end user after installation and internal wiring.
2. Do not allow pieces of metal, wire clippings, or fine metallic fillings from installation to enter the product or else it may lead to a safety hazard that may in turn endanger life or cause electrical shock to the operator.
3. Circuit breaker or mains switch must be installed between power source and supply terminal to facilitate power 'ON' or 'OFF' function. However this mains switch or circuit breaker must be installed at convenient place normally accessible to the operator.
4. Use and store the instrument within the specified ambient temperature and humidity ranges as mentioned in this manual.

WARNING GUIDELINES



WARNING : Risk of electric shock.

1. To prevent the risk of electric shock, power supply to the equipment must be kept OFF while doing the wiring arrangement. Do not touch the terminals while power is being supplied.
2. To reduce electro magnetic interference, use wire with adequate rating and twists of the same of equal size shall be made with shortest connection.
3. Cable used for connection to power source, must have a cross section of 1mm² or greater. These wires should have insulations capacity made of at least 1.5kV.
4. When extending the thermocouple lead wires, always use thermocouple compensation wires for wiring for the RTD type, use a wiring material with a small lead resistance (5Ω max per line) and no resistance differentials among three wires should be present.
5. A better anti-noise effect can be expected by using standard power supply cable for the instrument.



SAFETY PRECAUTION

All safety related codifications, symbols and instructions that appear in this operating manual or on the equipment must be strictly followed to ensure the safety of the operating personnel as well as the instrument.

If all the equipment is not handled in a manner specified by the manufacturer, it might impair the protection provided by the equipment.



Read complete instructions prior to installation and operation of the unit.



WARNING : Risk of electric shock.

FACTORY SETTING

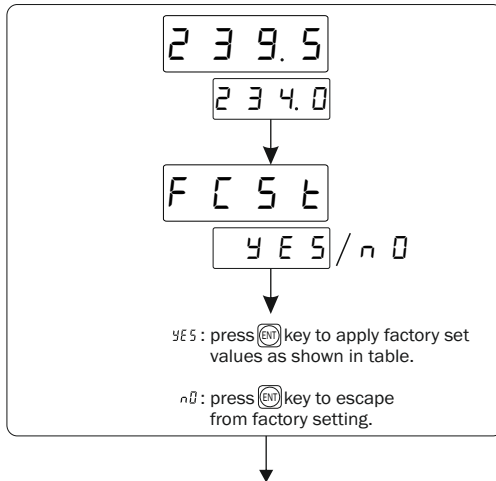

FACTORY SETTING

SR.	PARAMETER	VALUES
1	PB	20.0° C
2	IT	300
3	DT	75
4	CT	15 sec
5	MR	0° C
6	OFFSET	0° C
7	HYSTERISIS-1	3° C
8	HYSTERISIS-2	3° C
9	C-PB	4.0° C
10	C-ON	1 Sec
11	C-OFF	48 Sec
12	CRFC	0

PARAMETER MESSAGE DESCRIPTION

C. SEt	Controlling O/P Set Point
SEt 1	Set Point 1 For O/P 1
SEt 2	Set Point 2 For O/P 2
LOw 1	Low Set Point 1
HIG 1	High Set Point 1
LOw 2	Low Set Point 2
HIG 2	High Set Point 2
PASS	Password
INPt	Input (Sensor)
SLL	Set Low Limit
SHL	Set High Limit
OFFSt	Offset
Pb	Proportional Band For PID Action
It	Integral Time Constant
dT	Derivative Time Constant
Ct	Cycle Time For PID Action
r	Manual Reset
C-Pb	Cooling PB
C-On	Cooling On Time
C-OF	Cooling Off Time
HY5 1	Hysterisis 1

PARAMETER MESSAGE DESCRIPTION

HY52	Hysterisis 2
OUT 1	OutPut 1 Mode
SOAK	Soak Time Select
SPnd	Soak Mode
SPUt	Soak Unit
SPt n	Soak Time Value
nE n 0	Soak Time Memory
End	Soak Time End
Ctr 1	Control Action 1
OUT2	Output 2 Mode
Ctr 2	Control Action 2
ALn 1	Alarm 1
ALn 2	Alarm 2
S2nd	Set 2 Mode
r 1dL	Relay 1 Delay Time
r 2dL	Relay 2 Delay Time
ALt n	Alarm Time
Pi d	PID Action
OnOF	ON-OFF Action
bl.tP	Blower TP Action
HIGH	High Alarm
LOW	Low Alarm
Ob-t	OutBand Alarm
Ab-L	Absolute Low Alarm
In-b	In Band Alarm
Ab-O	Absolute Out Band Alarm
SEC	Second
n 1 n	Minute
HOUr	Hour
HEAt	Heating Mode
COOL	Cooling Mode
ALr n	Alarming Mode
OFF	OFF Mode
YES	Yes
n 0	No
SAvE	Save
IndI	Set 2 Individual to Set 1
rLt u	Set 2 Reletive to Set 1
FCSt	Factory Setting
ADUt	Analog Output
bASE	Basic Configuration
Pu	Retransmission O/P On PV
Su	Retransmission O/P On SV
4-20	Manual Selection Of 4-20 mA Analog O/P
PErC	Percentage wise Selection Of 4-20 mA Analog O/P (Manually)
COn	Controlling Output

RANGE FOR CONTROL PARAMETER

SR.	PARAMETER	RANGE FOR J,K,PT-100	RANGE FOR PT.1	RANGE FOR ANALOG INPUT	
1	PB	0.0 to 999.9 °C	0.0 to 999.9 °C	0.0 to 999.9	
2	IT	0 to 9999	0 to 9999	0 to 9999	
3	DT	0 to 9999	0 to 9999	0 to 9999	
4	CT	4 to 99 sec	4 to 99 sec	4 to 99 sec	
5	MR	-9 to 9 °C	-9.0 to 9.0 °C	DP 3	-0.099 to 0.099
				DP 2	-0.99 to 0.99
				DP 1	-9.9 to 9.9
				DP 0	-99 to 99
6	OFFSET	-20 to 20 °C	-20.0 to +20.0 °C	DP 3	-0.999 to 0.999
				DP 2	-9.99 to 9.99
				DP 1	-99.9 to 99.9
				DP 0	-999 to 999
7	HYS1	1 to 100 °C	0.1 to 100.0 °C	DP 3	0.001 to 0.999
				DP 2	0.01 to 9.99
				DP 1	0.1 to 99.9
				DP 0	1 to 999
8	HYS2	1 to 100 °C	0.1 to 100.0 °C	DP 3	0.001 to 0.999
				DP 2	0.01 to 9.99
				DP 1	0.1 to 99.9
				DP 0	1 to 999
9	C-PB	2.0 to 25.0 °C	2.0 to 25.0 °C	2.0 to 25.0	
10	C-ON	1 to 20 sec	1 to 20 sec	1 to 20 sec	
11	C-OF	5 to 200 sec	5 to 200 sec	5 to 200 sec	
12	R1DL	0.00 to 99.59 mm.ss	0.0 to 99.59 mm.ss	0.00 to 99.59 mm.ss	
13	R2DL	0.00 to 99.59 mm.ss	0.0 to 99.59 mm.ss	0.00 to 99.59 mm.ss	
14	ALTM	0 to 99 sec	0 to 99 sec	0 to 99 sec	
15	CRFC	-	-	DP 3	-0.999 to 0.999
				DP 2	-9.99 to 9.99
				DP 1	-99.9 to 99.9
				DP 0	-999 to 999
16	FLTR	-	-	0.1 to 10.0 Sec	
17	SLL	-	-	0.0 to 5.0 mA	

PARAMETER SETTING

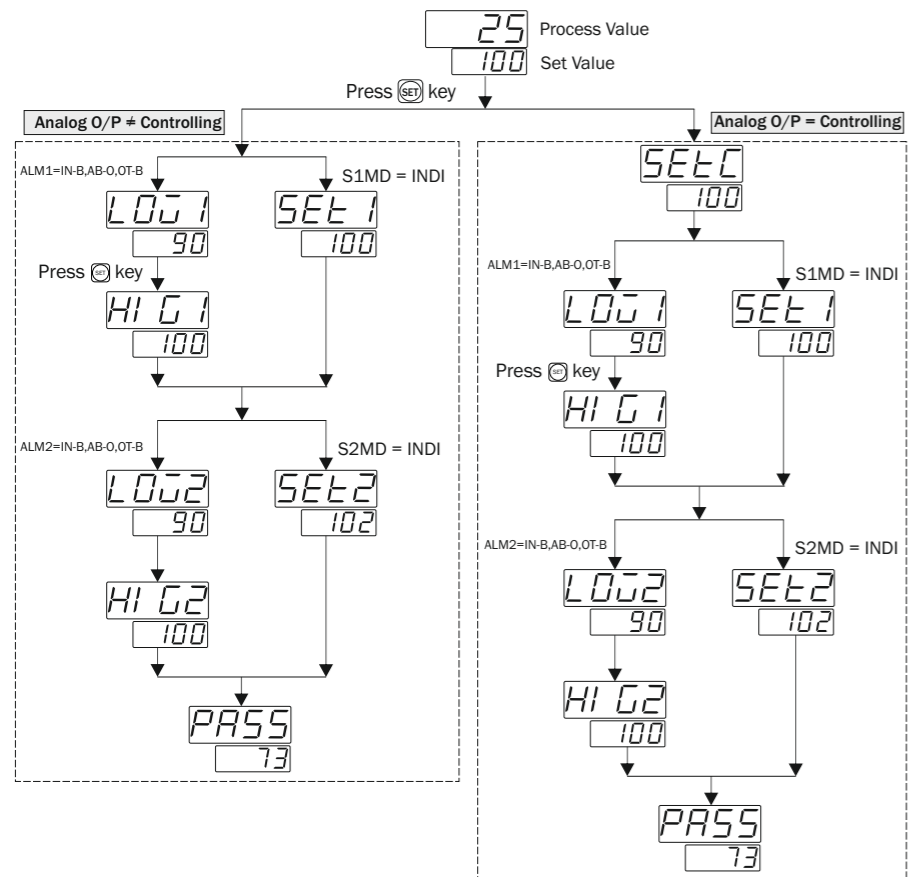

Parameter 1 : Basic Configuration (bASE)

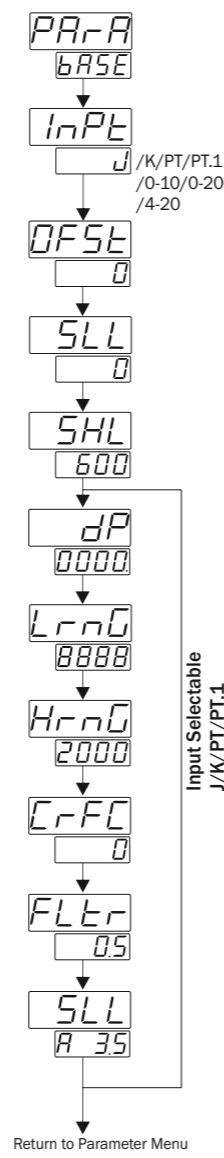

Parameter 2 : Relay 1 (rLY1)

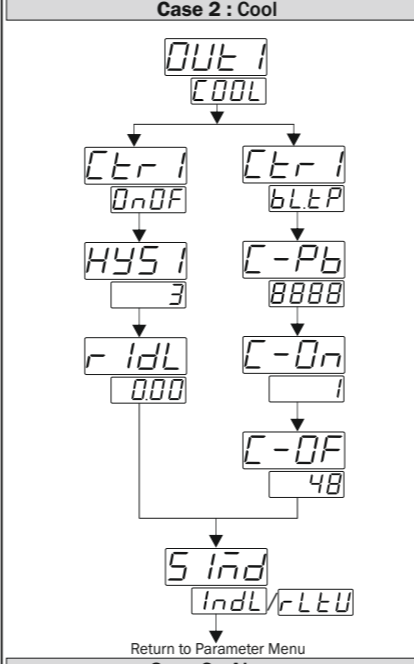
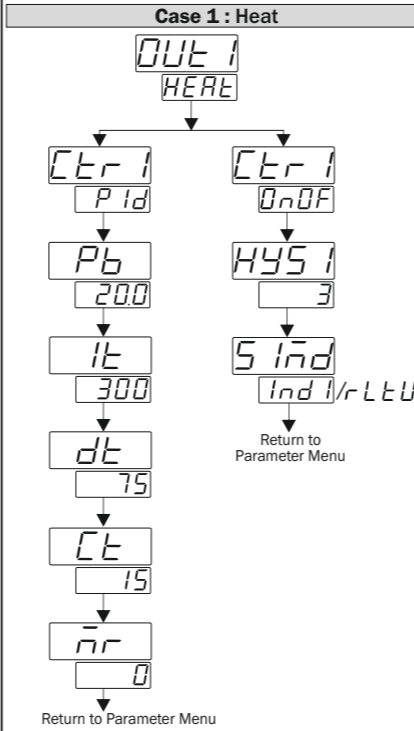

Parameter 3 : Relay 2 (rLY2)

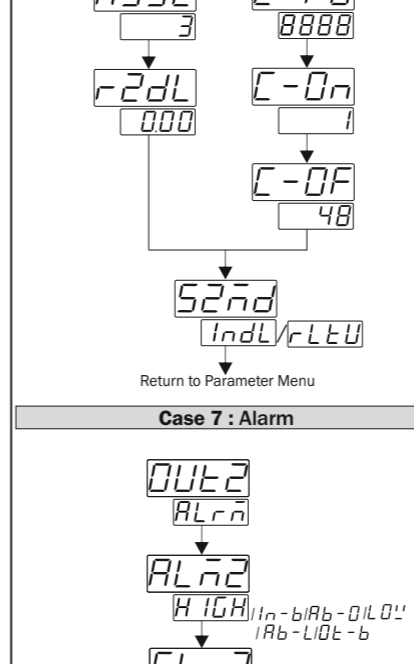
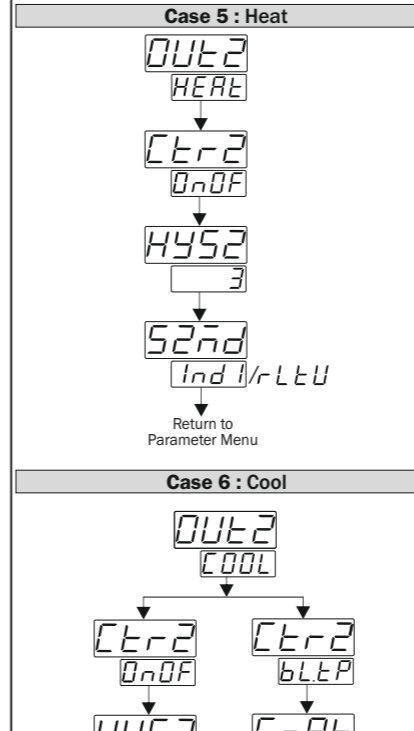

Parameter 4 : Analog Output (AOUT)

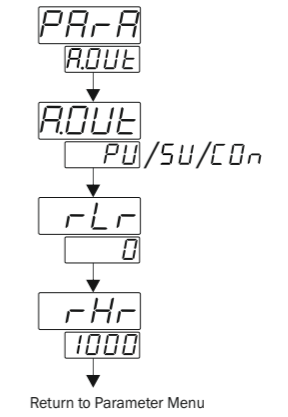

Parameter 5 : Soak Timer (SOAK)

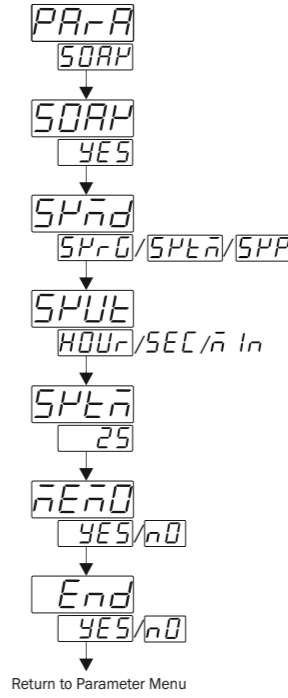

Parameter 6 : Modbus Setting (nBUS)

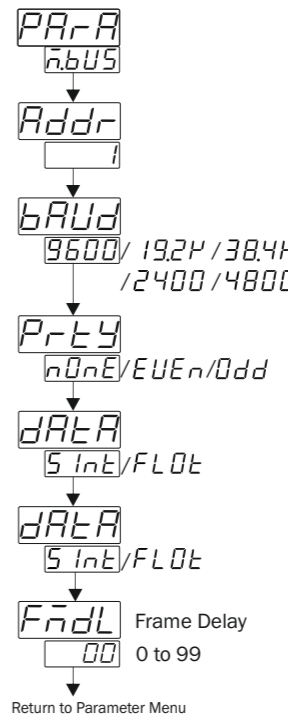

Password 73 Explanation

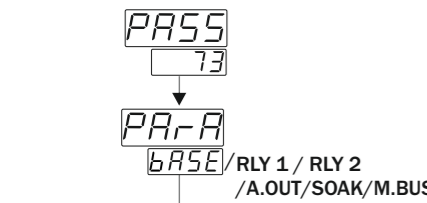

- Parameter 1 : Basic Configuration (bASE)
- Parameter 2 : Relay 1 (rLY1)
 - Case 1 : Heat
 - Case 2 : Cool
 - Case 3 : Alarm
 - Case 4 : Off
- Parameter 3 : Relay 2 (rLY2)
 - Case 5 : Heat
 - Case 6 : Cool
 - Case 7 : Alarm
 - Case 8 : Off
- Parameter 4 : Analog Output (AOUT)
- Parameter 5 : Soak Timer (SOAK)
- Parameter 6 : Modbus (nBUS)

Note : In case 4 & 8 relay will be in off condition

Case 4 & 8 : OFF



To set Controlling Output Mode press SET + [] key

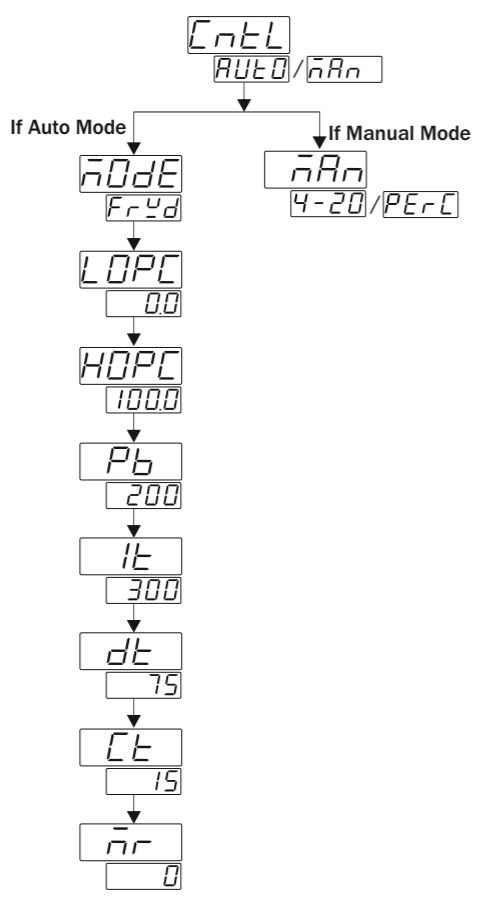

CONTROL FUNCTION

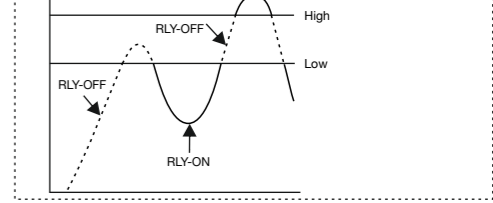
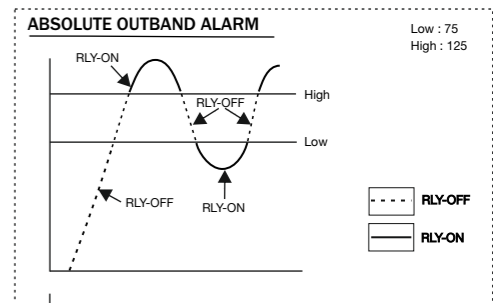
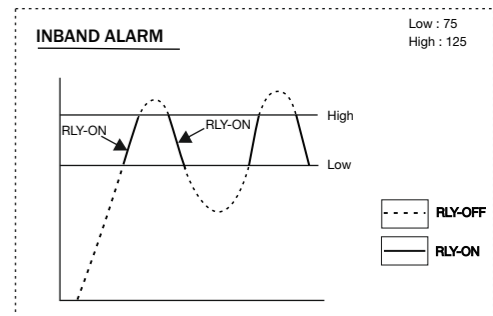
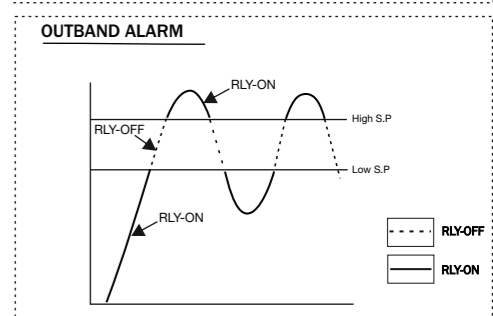
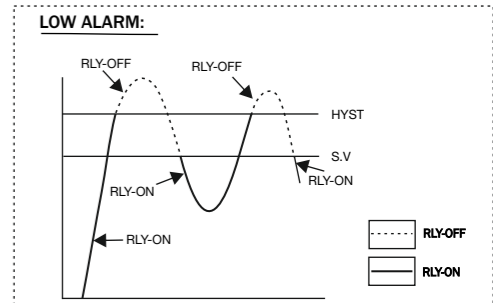
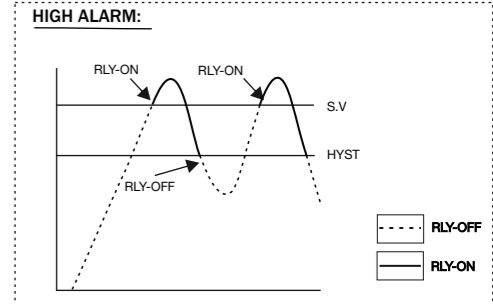

MODBUS

Slave Address :	1 to 127
Baudrate :	2400,4800,9600,38400bps
Parity :	None,Even,Odd
Datatype :	Sign integer, Float (32 Bit Little Endian Byte Swap)
Read Function Register :	0x03 and 0x04
Write Function Register :	0x06 and 0x10

Note :- When Parameter 32100 = no available
 When Process Value 32101 = Initialization Value
 When Process Value 32102 = Sensor Open
 When Process Value 32103 = Sensor Reverse
 When Process Value 32104 = Over Range
 When Process Value 32105 = I/P Signal Lower then SLL

Sr.No	Access Type	Parameter	Register	
			Data Type	Integer
1	R	Process Value	0	0
2	R	R1 Status	1	2
		Selection Value		
		On	1	
		Off	0	
3	R	R2 Status	2	4
		Selection Value		
		On	1	
		Off	0	
4	R	Control Percentage	3	6
5	R	Analog Output Value	4	8
6	R/W	Cset1	5	10
7	R/W	Low Set1	6	12
8	R/W	High Set1	7	14
9	R/W	Set2	8	16
10	R/W	Low Set2	9	18
11	R/W	High Set2	10	20
12	R/W	Set3	11	22
13	R/W	Low Set3	12	24
14	R/W	High Set3	13	26
15	R/W	Input	14	28
		Selection Value		
		J	0	
		K	1	
		PT-100	2	
		PT.1	3	
		0 - 10V DC	4	
		0 - 20mA DC	5	
		4 - 20mA DC	6	
16	R/W	Out1 Mode	15	30
		Selection Value		
		Heat	0	
		Cool	1	
		Alarm	2	
		Off Mode	3	
17	R/W	Control Action1	16	32
		Selection Value		
		Pid	0	
		On-Off	1	
		Blower TP	2	

Sr.No	Access Type	Parameter	Register	
			Data Type	Integer
18	R/W	Alarm1	17	34
		Selection Value		
		End Alarm	0	
		Abs Low	1	
		High Alarm	2	
		In Band	3	
		Abs Out Band	4	
		OT - b	5	
		Log	6	
19	R/W	Hys1	18	36
20	R/W	Delay Time1	19	38
21	R/W	Alarm Time1	20	40
22	R/W	Out2 Mode	21	42
		Selection Value		
		Heat	0	
		Cool	1	
		Alarm	2	
		Off Mode	3	
23	R/W	Control Action2	22	44
		Selection Value		
		Pid	0	
		On-Off	1	
		Blower TP	2	
24	R/W	Alarm2	23	46
		Selection Value		
		End Alarm	0	
		Abs Low	1	
		High Alarm	2	
		In Band	3	
		Abs Out Band	4	
25	R/W	Hys2	24	48
26	R/W	Delay Time2	25	50
27	R/W	Alarm Time2	26	52
28	R/W	Set2 Mode	27	54
		Selection Value		
		Individual	0	
		Relative	1	
29	R/W	Out3 Mode	28	56
		Selection Value		
		Heat	0	
		Cool	1	
		Alarm	2	
		Off Mode	3	
30	R/W	Control Action3	29	58
		Selection Value		
		Pid	0	
		On-Off	1	
		Blower TP	2	
31	R/W	Alarm3	30	60
		Selection Value		
		End Alarm	0	
		Abs Low	1	
		High Alarm	2	
		In Band	3	
		Abs Out Band	4	

Sr.No	Access Type	Parameter	Register	
			Data Type	Integer
32	R/W	Hys3	31	62
33	R/W	Delay Time3	32	64
34	R/W	Alarm Time3	33	66
35	R/W	Set3 Mode	34	68
		Selection Value		
		Individual	0	
		Relative	1	
36	R/W	Soak	35	70
37	R/W	Soak Mode	36	72
		Selection Value		
		Soak Time Normal	0	
		Soak Pass	1	
		Soak Remaining	2	
38	R/W	Soak Unit	37	74
		Selection Value		
		Sec	0	
		Min	1	
		Hour	2	
39	R/W	Soak Time	38	76
40	R/W	Memory	39	78
		Selection Value		
		NO	0	
		Yes	1	
41	R/W	End Save	40	80
42	R	Run Soak Value	41	82
43	R	Soak Status	42	84
		Selection Value		
		End	0	
		Run	1	
		Hold	2	
44	R/W	Set Low Limit	43	86
45	R/W	Set High Limit	44	88
46	R/W	Offset	45	90
47	R/W	DP Process	46	92
		Selection Value		
		0000	0	
		000.0	1	
		00.00	2	
		0.000	3	
48	R/W	Low Range	47	94
49	R/W	High Range	48	96
50	R/W	CRFC	49	98
51	R/W	FLTR Process	50	100
52	R/W	Signal Low Limit	51	102
53	R/W	PB	52	104
54	R/W	IT	53	106
55	R/W	DT	54	108
56	R/W	CT	55	110
57	R/W	MR	56	112
58	N/A	N/A	N/A	N/A
59	N/A	N/A	N/A	N/A
60	R/W	C PB	59	118
61	R/W	C ON	60	120
62	R/W	C OF	61	122

Sr.No	Access Type	Parameter	Register	
			Data Type	Integer
63	R/W	Auto Tune	62	124
		Selection Value		
		No	0	
		Yes	1	
64	R/W	Address	63	126
65	R/W	Baudrate	64	128
		Selection Value		
		B 2400	0	
		B 4800	1	
		B 9600	2	
		B 19200	3	
		B 38400	4	
66	R/W	Parity	65	130
		Selection Value		
		None	0	
		Even	1	
		Odd	2	
67	R/W	Data Type	66	132
		Selection Value		
		Sign Integer	0	
		Float	1	
68	R/W	Analog Output Type	67	134
69	R/W	RT Low Range	68	136
70	R/W	RT High Range	69	138
71	R/W	Control Mode	70	140
		Selection Value		
		Forward	1	
		Reverse	0	
72	R/W	Low Percentage	71	142
73	R/W	High Percentage	72	144
74	R/W	Framedelay	82	164

Data type = Sign Integer show value as per following

Input	Actual Value	DP Selection
J,K,Pt	Value/1	Fix
Pt.1	Value/10	Fix
Where Parameter is 1,6-14,19,25,32,44-46,48,49,57,69,70		
0-10V DC	Value/1	0
0-20 mA DC	Value/10	1
4-20mA DC	Value/100	2
	Value/1000	3
Where Parameter is 5 ,20,26,33		
0-10V DC	Value/10	Fix
0-20 mA DC		
4-20mA DC		
Where Parameter is 4,51-53,72,73		
0-10V DC	Value/100	Fix
0-20 mA DC		
4-20mA DC		