

Johannesburg Branch

MIMIC COMPONENTS

Cape Town Branch

Mimic Cape

MULTISPAN



HUMIDITY + TEMPERATURE CONTROLLER

MHT 1202

APPLICATIONS

Process industries

Lab Testing equipment

Testing Chambers

HVAC & Refrigeration industries

Mechanical Dimensions

Body Dimensions

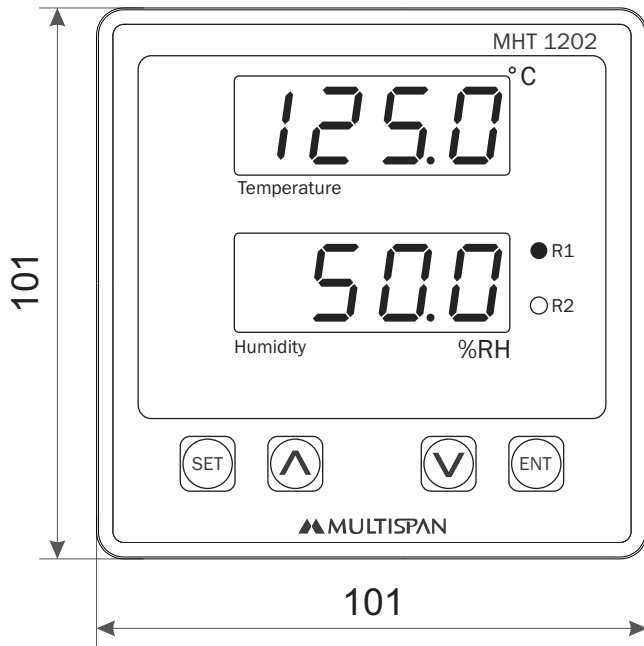

FRONT VIEW

All dimensions are in mm

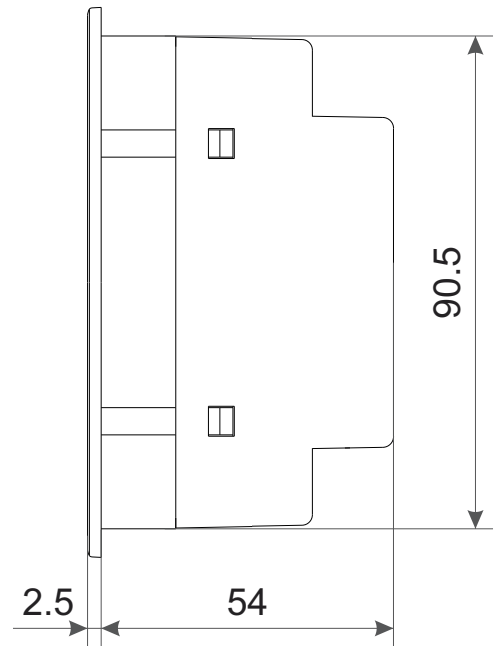

RIGHT SIDE VIEW

Connection Diagram

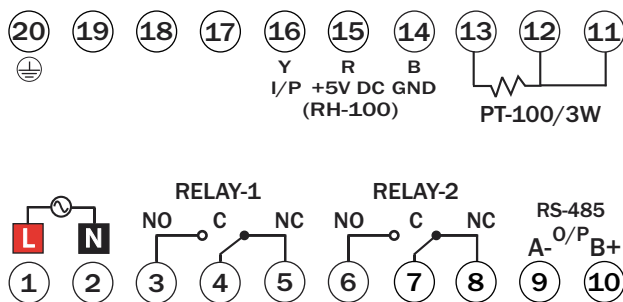

Panel Cutout

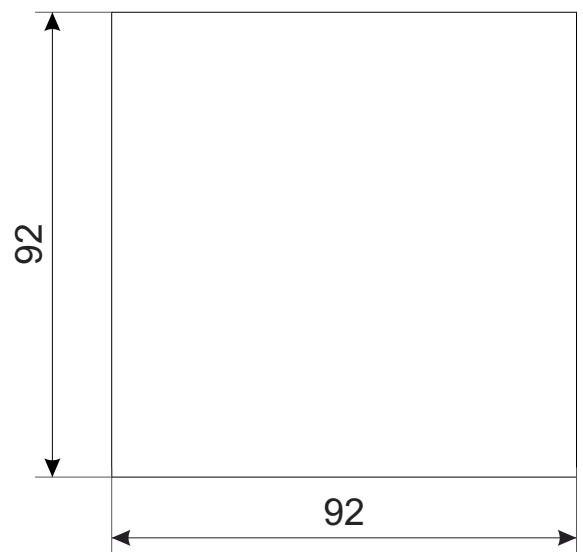

TECHNICAL DATA

Input	S1 : RTD, PT 100/3W Sensor S2 : Humidity Sensor (RH-100)
Range	0.0 to 400.0 °C 0.0 to 100.0 % RH
Output	2 Relay
Alarm	High / Low Alarm (ON-OFF Action)
Communication (Optional)	RS-485 Modbus
Power Supply	100-270V AC ,50/60Hz, Approx 4VA

Input	
Input	S1 : RTD, PT 100/3W Sensor S2 : Humidity Sensor (RH-100)
Range	0.0 to 400.0 °C 0.0 to 100.0% RH
Resolution	0.1 %
Accuracy	± 1% of FSD
ADC Resolution	10 Bit
Sample Time	600 msec
CJC Error	± 2 °C
Sensor Open	PT 100 & RH 100
Sensor Burnout Current	1.10uA
CMRR	>120 dB (Typical)
Max Voltage	20V DC
Response Time	675mS

Auxiliary Power Supply	
Power Supply	100 to 270V AC, 50/60Hz
Burden	4VA

Output	
Relays	2 Nos
Relay Type	1C/O (NO-C-NC)
Rating	5A, 230V AC / 30V DC

Display LED & Keys		
Display	Upper	4 Digit 7 seg 0.36" Red LED
	Lower	4 Digit 7 seg 0.36" White LED
Key	SET, INC, DEC, ENT	
LED Indication	R1, R2	

Communication	
Type	RS 485
Protocol	MODBUS RTU
Baud Rate	2400 , 4800 , 9600 , 19200 , 38400
Isolation	2500 V _{RMS} Isolation as per UL 1577

Note :

Accurate sensing of humidity is subject to proper mounting of humidity sensor as per application area. Please consult our support engineers if needed.

Environmental Characteristics

Working Temperature	0 to 55 °C
Storage Temperature	0 to 55 °C
Relative Humidity	95% RH Non-condensing
Warm up time	5 minutes

Mechanical Characteristics

Mounting Type	Panel Mount
Dimension (HxWxD) mm	101 x 101 x 54
Panel Cutout (HxW) mm	92 x 92
Material	Front: Polycarbonate (PC) Enclosure: ABS
Terminal Screw Size	M3.5
Screw Torque (N.m)	0.5
Wire Gauge (AWG)	26-14
Weight (Approx) gms	Unpacked : 200 Packed : 230
Accessories	1 Pair of Mounting Clamps